



Understanding oceans
Sustaining future



Update on HM4000 float

Zhaohui CHEN^{1,2}, Chong REN¹ and Zenghong LIU^{3,4}

- 1) Qingdao National Laboratory for Marine Science and Technology (QNLN)
- 2) Ocean University of China (OUC)
- 3) State Key Laboratory of Satellite Ocean Environment Dynamics (SOED)
- 4) The Second Institute of Oceanography, Ministry of Natural Resources (CSIO)

Main progress in 2020

- HM4000 prototype upgraded in terms of testing processes and manufacture
- Deep floats for 6000 m (HM6000) under development
- Tentative deployment in the Western Pacific in May 2021

Hardware of the control system

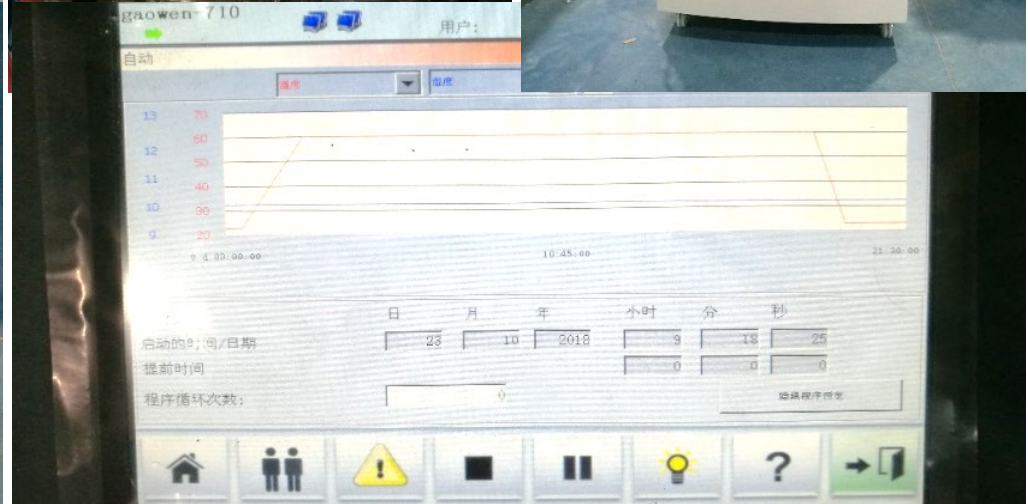
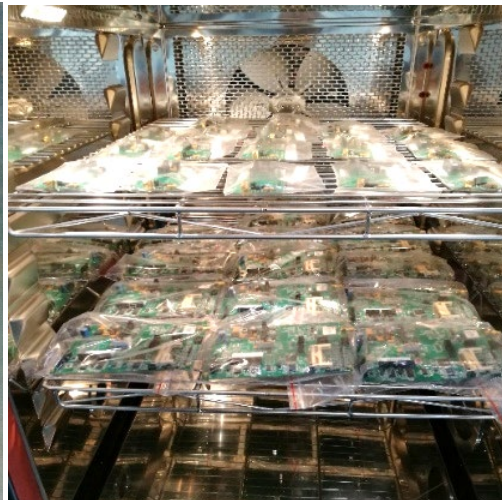

Buoyancy drive devices updated



- 10 sets of buoyancy drive devices have been assembled.
- Onshore cycle test and pressure test have been completed.

Assembly and Test



- Assembly of 10 prototypes has been completed.
- 1 prototype has been completed in the lake test.
- 1 prototype is about to be tested in the SCS.

Prototypes of HM4000

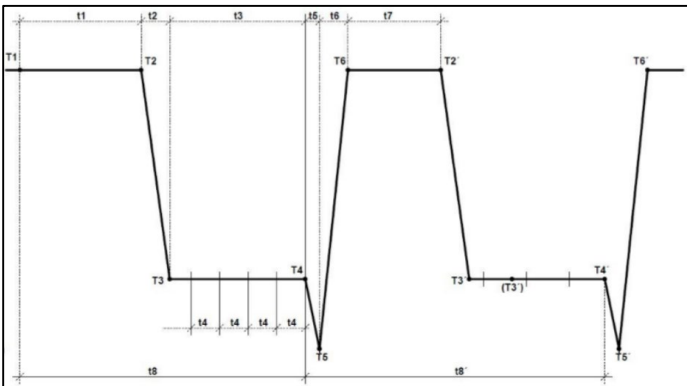
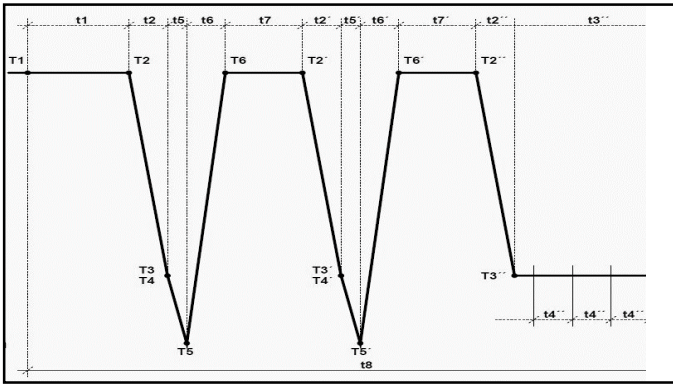

- Parking depth: 500 m to 4000 m
nominal parking depth 1000 m
- Adjustable ascending/descending speed
- Safety strategy
grounding detection
emergent ascending for a time-out or
an excessive profiling
- Low-power strategy

Prototypes of HM4000

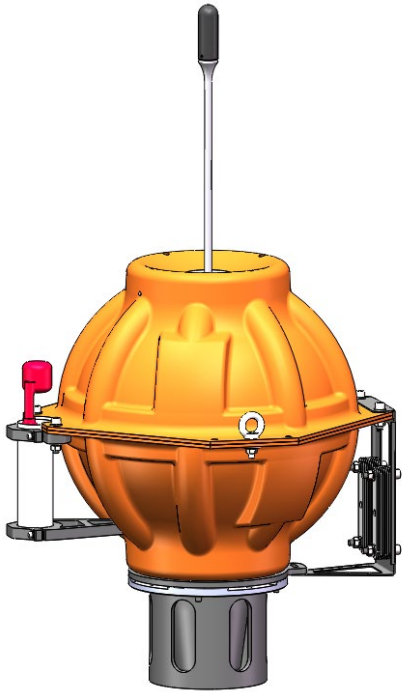

RBRARGO3 CTD



SEB61 CTD

- There will be 10 HM4000 floats to be deployed, with 9 of them are equipped with RBRARGO3 CTD and only one with SEB61.

Tentative deployment

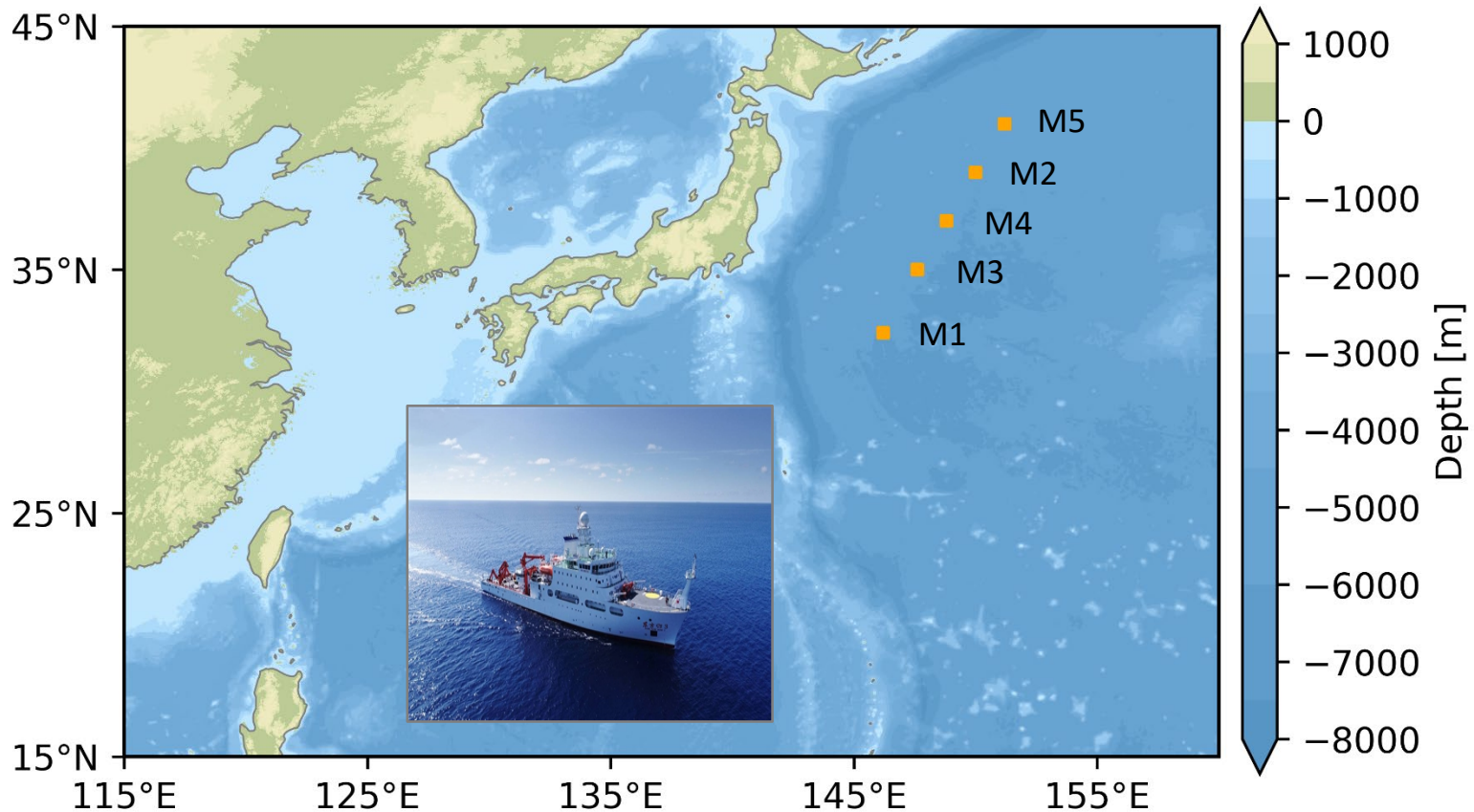

- Upcoming cruise: the Northwestern Pacific Ocean (probably from 10 May to 20 June)
- 10 deep floats at five locations, with 2 floats at each location

Tentative deployment

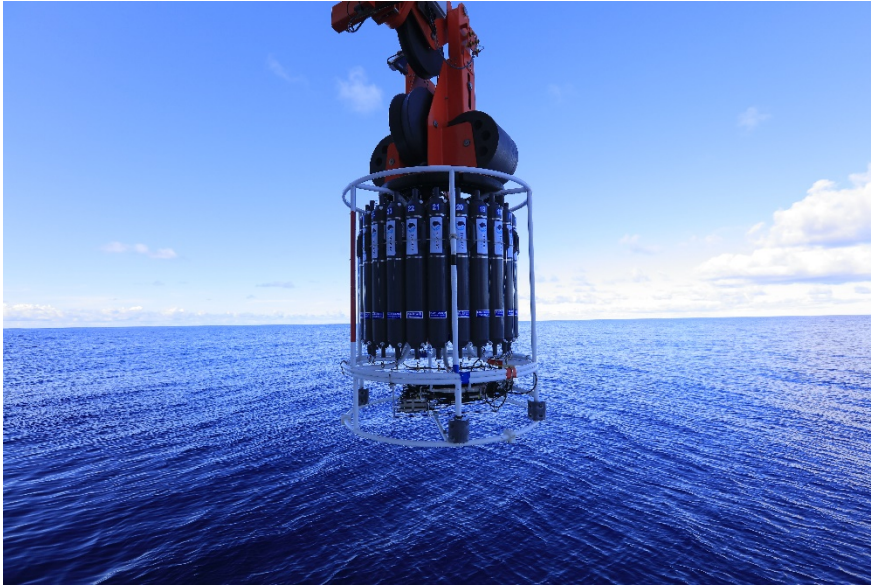

- The sea water will be sampled by CTD rosettes of the RV after HM4000 floats are deployed.
- A salinometer on-board to measure the salinity of sea water at certain depths.

Thank you for your attention!



Zhaohui Chen
(QNLN/OUC)

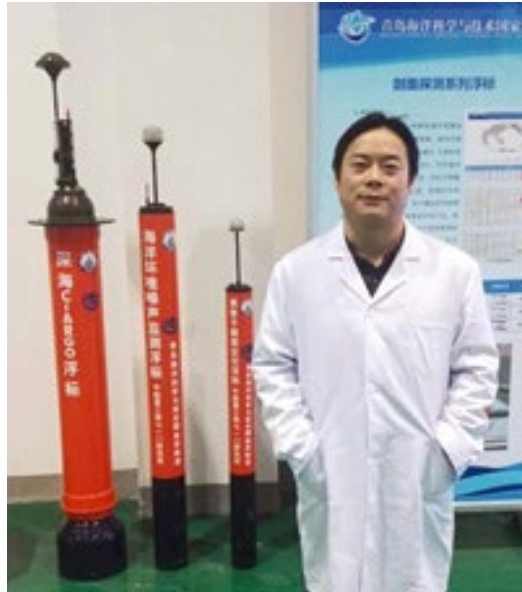

Chong Ren
(QNLN)

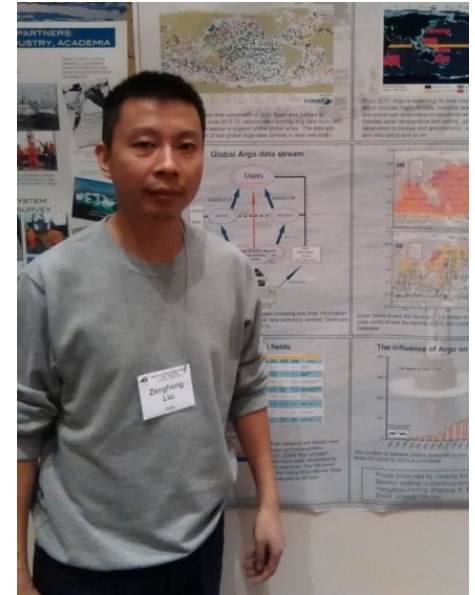

Zenghong Liu
(CSIO)